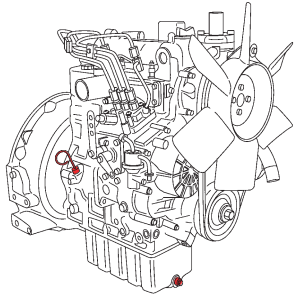
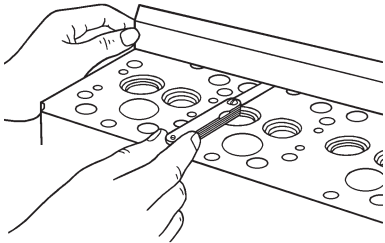
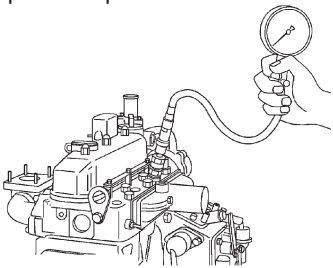
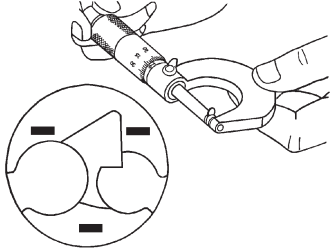
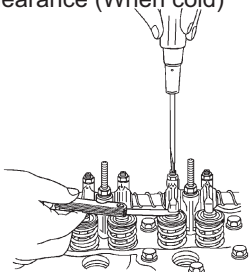
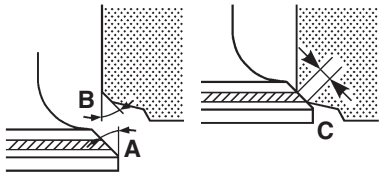
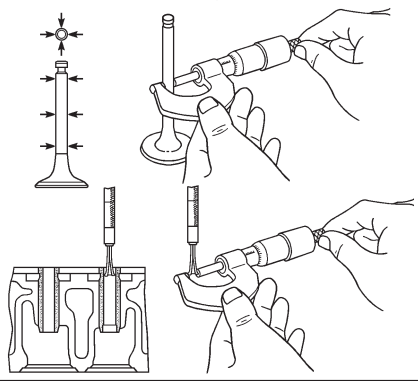
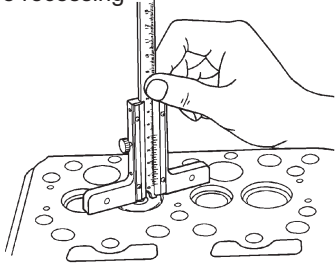
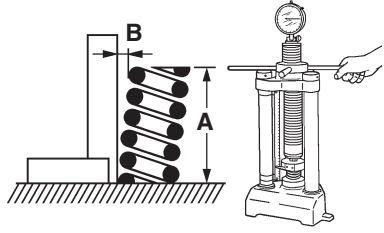
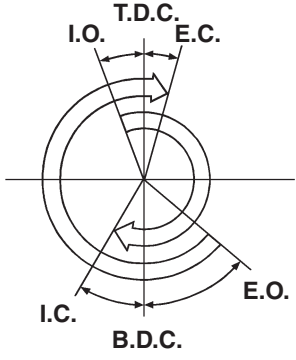
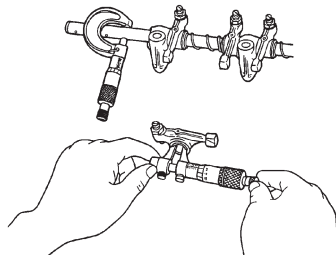
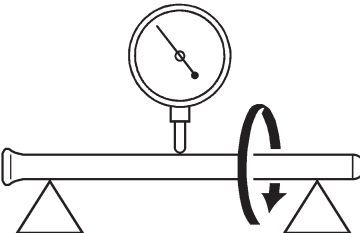
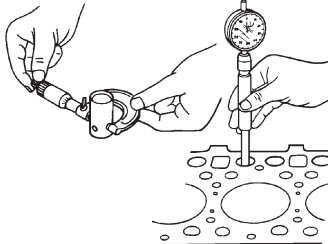

SERVICING SPECIFICATIONS

(1) ENGINE BODY

| Item | | | Factory Specification | Allowable Limit |
|---|------------------------------------|---|--|---|
| Lubricating oil capacity  | Oil pan depth 125 mm (4.92 in.) | D905-EB D1005-EB D1105-EB D1105-T-EB | 5.1 L 1.35 U.S.gals. 1.12 Imp.gals. | — |
| | | V1205-EB V1305-EB V1505-EB | 6.0 L 1.59 U.S.gals. 1.32 Imp.gals. | — |
| | | V1205-T-EB V1505-T-EB | 6.7 L 1.77 U.S.gals. 1.47 Imp.gals. | — |
| | Oil pan depth 101 mm (3.98 in.) | D905-EB D1005-EB D1105-EB D1105-T-EB | 4.0 L 1.06 U.S.gals. 0.88 Imp.gals. | — |
| | | V1205-EB V1305-EB V1505-EB | 4.7 L 1.24 U.S.gals. 1.03 Imp.gals. | — |
| | | V1205-T-EB V1505-T-EB | — | — |
| Cylinder head surface  | Flatness | All models | — | 0.05 mm / 500 mm 0.0020 in. / 19.69 in. |
| Compression pressure  | | All models | 2.84 to 3.23 MPa 29.0 to 33.0 kgf/cm ² 412 to 469 psi | 2.25 MPa 23.0 kgf/cm ² 327 psi |
| Top clearance  | | All models | 0.55 to 0.75 mm 0.0217 to 0.0295 in. | — |

| Item | | Factory Specification | Allowable Limit |
|--|----------------------------------|--|---|
| Valve clearance (When cold)  | | All models 0.145 to 0.185 mm 0.00571 to 0.00728 in. | — |
| Valve & valve seat  | Face angle (A) (Intake) | All models 1.047 rad. 60° | — |
| | Face angle (A) (Exhaust) | All models 0.785 rad. 45° | — |
| | Seat angle (B) (Intake) | All models 1.047 rad. 60° | — |
| | Seat angle (B) (Exhaust) | All models 0.785 rad. 45° | — |
| | Seat width (C) (Intake) | All models 2.12 mm 0.0835 in. | — |
| | Seat width (C) (Exhaust) | All models 2.12 mm 0.0835 in. | — |
| Valve stem to valve guide  | Clearance | All models 0.035 to 0.065 mm 0.00138 to 0.00256 in. | 0.1 mm 0.0039 in. |
| | Valve stem O.D. | All models 6.960 to 6.975 mm 0.27402 to 0.27461 in. | — |
| | Valve guide I.D. | All models 7.010 to 7.025 mm 0.27598 to 0.27657 in. | — |
| Valve recessing  | | All models 0.05 mm (Protrusion) to 0.25 mm (Recessing) 0.0020 in. (Protrusion) to 0.0098 in. (Recessing) | 0.4 mm (Recessing) 0.0157 in. (Recessing) |
| Valve spring  | Free length (A) | All models 37.0 to 37.5 mm 1.457 to 1.476 in. | 36.5 mm 1.437 in. |
| | Tilt (B) | All models — | 1.0 mm 0.039 in. |
| | Setting load / Setting length | All models 117.4 N / 31.0 mm 11.97 kgf / 31.0 mm 26.4 lbs / 1.220 in. | 100.0 N / 31.0 mm 10.2 kgf / 31.0 mm 22.5 lbs / 1.220 in. |

| Item | Factory Specification | | Allowable Limit | |
|---|--------------------------|---|---|-----------------------|
| <p>Valve timing</p>  | Open (Intake valve) | D905-EB D1005-EB D1105-EB V1205-EB V1205-T-EB V1305-EB V1505-EB | 0.24 rad. before T.D.C. 14° before T.D.C. | — |
| | | D1105-T-EB V1505-T-EB | 0.38 rad. before T.D.C. 22° before T.D.C. | — |
| | Close (Intake valve) | D905-EB D1005-EB D1105-EB V1205-EB V1205-T-EB V1305-EB V1505-EB | 0.52 rad. after B.D.C. 30° after B.D.C. | — |
| | | D1105-T-EB V1505-T-EB | 0.82 rad. after B.D.C. 47° after B.D.C. | — |
| | Open (Exhaust valve) | D905-EB D1005-EB D1105-EB V1205-EB V1205-T-EB V1305-EB V1505-EB | 0.96 rad. before B.D.C. 55° before B.D.C. | — |
| | | D1105-T-EB V1505-T-EB | 0.91 rad. before B.D.C. 52° before B.D.C. | — |
| <p>Rocker arm shaft to rocker arm</p>  | Clearance | All models | 0.016 to 0.045 mm 0.00063 to 0.00177 in. | 0.1 mm 0.0039 in. |
| | Rocker arm shaft O.D. | All models | 11.973 to 11.984 mm 0.47138 to 0.47181 in. | — |
| | Rocker arm I.D. | All models | 12.000 to 12.018 mm 0.47244 to 0.47315 in. | — |
| <p>Push rod</p>  | Alignment | All models | — | 0.25 mm 0.0098 in. |
| <p>Tappet to tappet guide</p>  | Clearance | All models | 0.020 to 0.062 mm 0.00079 to 0.00244 in. | 0.07 mm 0.0028 in. |
| | Tappet O.D. | All models | 19.959 to 19.980 mm 0.78579 to 0.78661 in. | — |
| | Tappet guide I.D. | All models | 20.000 to 20.021 mm 0.78740 to 0.78823 in. | — |

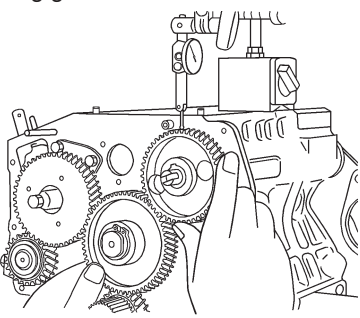
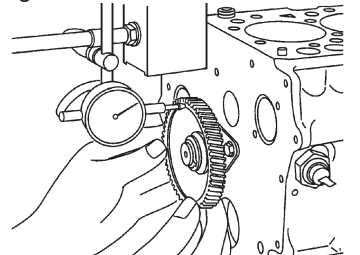
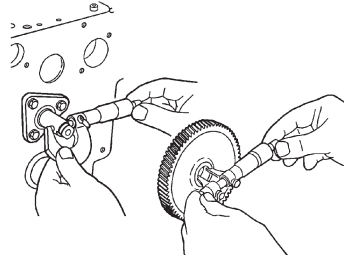
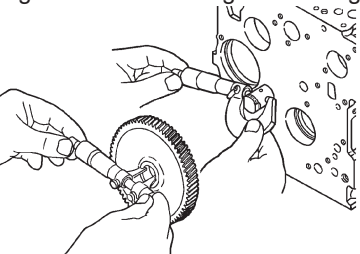
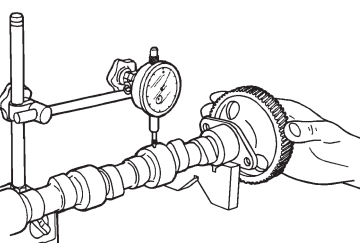
| Item | | | Factory Specification | Allowable Limit |
|---|---|---------------------------|---|-----------------------|
|  <p>Timing gear</p> | Backlash (Crank gear to idle gear 1) | All models | 0.032 to 0.115 mm 0.00126 to 0.00453 in. | 0.15 mm 0.0059 in. |
| | Backlash (Idle gear 1 to cam gear) | All models | 0.036 to 0.114 mm 0.00142 to 0.00449 in. | 0.15 mm 0.0059 in. |
| | Backlash (Idle gear 1 to injection pump) | All models | 0.034 to 0.116 mm 0.00134 to 0.00457 in. | 0.15 mm 0.0059 in. |
| | Backlash (Injection pump gear to governor gear) | All models | 0.030 to 0.117 mm 0.00118 to 0.00461 in. | 0.15 mm 0.0059 in. |
| | Backlash (Idle gear 1 to idle gear 2) | Equipped with idle gear 2 | 0.033 to 0.117 mm 0.00130 to 0.00461 in. | 0.15 mm 0.0059 in. |
| | Backlash (Idle gear 2 to governor gear) | Equipped with idle gear 2 | 0.030 to 0.117 mm 0.00118 to 0.00461 in. | 0.15 mm 0.0059 in. |
|  <p>Idle gear</p> | Side clearance (Idle gear 1) | All models | 0.20 to 0.51 mm 0.0079 to 0.0201 in. | 0.8 mm 0.0315 in. |
| | Side clearance (Idle gear 2) | Equipped with idle gear 2 | 0.20 to 0.51 mm 0.0079 to 0.0201 in. | 0.8 mm 0.0315 in. |
|  <p>Idle gear shaft 1 to idle gear bushing</p> | Clearance | All models | 0.020 to 0.054 mm 0.00079 to 0.00213 in. | 0.1 mm 0.0039 in. |
| | Idle gear shaft 1 O.D. | All models | 25.967 to 25.980 mm 1.02232 to 1.02283 in. | — |
| | Idle gear bushing I.D. | All models | 26.000 to 26.021 mm 1.02362 to 1.02445 in. | — |
|  <p>Idle gear shaft 2 to idle gear bushing</p> | Clearance | All models | 0.020 to 0.054 mm 0.00079 to 0.00213 in. | 0.1 mm 0.0039 in. |
| | Idle gear shaft 2 O.D. | All models | 25.967 to 25.980 mm 1.02232 to 1.02283 in. | — |
| | Idle gear bushing I.D. | All models | 26.000 to 26.021 mm 1.02362 to 1.02445 in. | — |
|  <p>Camshaft</p> | Alignment | All models | — | 0.01 mm 0.0004 in. |

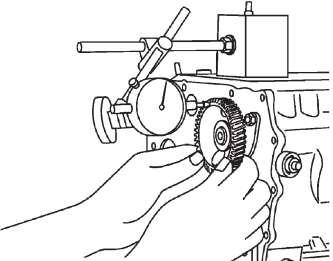
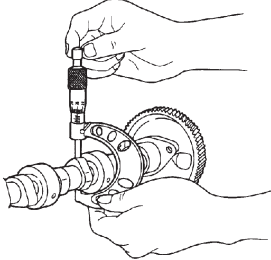
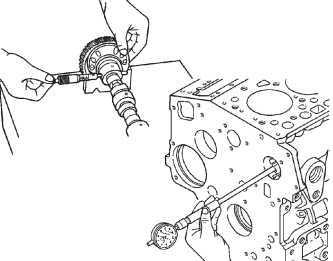
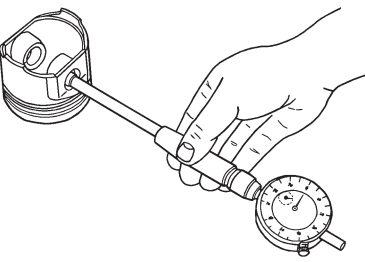
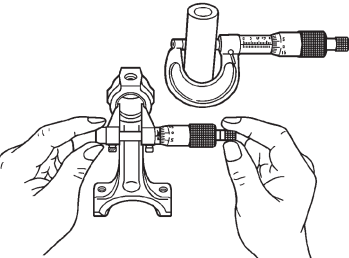
| Item | | | Factory Specification | Allowable Limit |
|--|--------------------------|------------|---|------------------------|
| Camshaft  | Side clearance | All models | 0.07 to 0.22 mm 0.0028 to 0.0087 in. | 0.3 mm 0.0118 in. |
| Cam  | Height (Intake) | All models | 28.80 mm 1.1339 in. | 28.75 mm 1.1319 in. |
| | Height (Exhaust) | All models | 29.00 mm 1.1417 in. | 28.95 mm 1.1398 in. |
| Camshaft journal to cylinder block bore  | Oil clearance | All models | 0.050 to 0.091 mm 0.00197 to 0.00358 in. | 0.15 mm 0.0059 in. |
| | Camshaft journal O.D. | All models | 35.934 to 35.950 mm 1.41472 to 1.41535 in. | — |
| | Cylinder block bore I.D. | All models | 36.000 to 36.025 mm 1.41732 to 1.41830 in. | — |
| Piston pin bore  | Piston pin bore I.D. | All models | 22.000 to 22.013 mm 0.86614 to 0.86665 in. | 22.03 mm 0.8673 in. |
| Piston pin to small end bushing  | Clearance | All models | 0.014 to 0.038 mm 0.00055 to 0.00150 in. | 0.15 mm 0.0059 in. |
| | Piston pin O.D. | All models | 22.002 to 22.011 mm 0.86622 to 0.86657 in. | — |
| | Small end bushing I.D. | All models | 22.025 to 22.040 mm 0.86712 to 0.86771 in. | — |

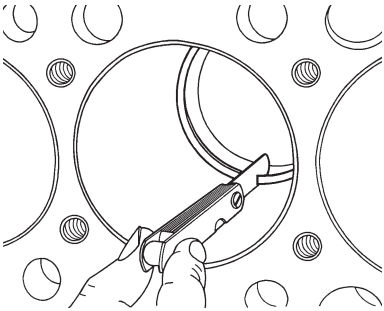
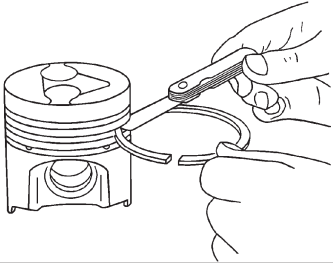
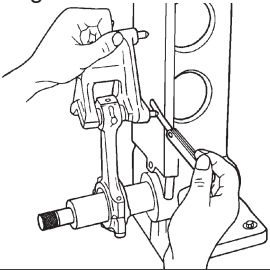
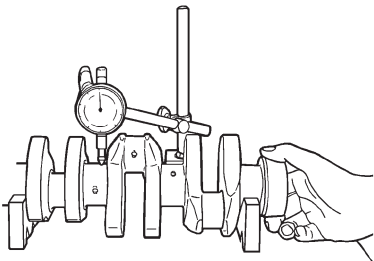
| Item | | Factory Specification | Allowable Limit | |
|---|--|---|---|---|
| Piston ring  | Ring gap (Top ring) | D905-EB V1205-EB | 0.25 to 0.40 mm 0.0098 to 0.0157 in. | 1.25 mm 0.0492 in. |
| | | D1005-EB D1105-EB V1305-EB V1505-EB | 0.30 to 0.45 mm 0.0118 to 0.0177 in. | 1.25 mm 0.0492 in. |
| | | D1105-T-EB V1205-T-EB V1505-T-EB | 0.20 to 0.35 mm 0.0079 to 0.0138 in. | 1.20 mm 0.0472 in. |
| | Ring gap (Second ring) | D905-EB V1205-EB | 0.25 to 0.40 mm 0.0098 to 0.0157 in. | 1.25 mm 0.0492 in. |
| | | D1005-EB D1105-EB V1305-EB V1505-EB | 0.30 to 0.45 mm 0.0118 to 0.0177 in. | 1.25 mm 0.0492 in. |
| | | V1205-T-EB | 0.20 to 0.35 mm 0.0079 to 0.0138 in. | 1.20 mm 0.0472 in. |
| | | D1105-T-EB V1505-T-EB | 0.40 to 0.55 mm 0.0157 to 0.0217 in. | 1.20 mm 0.0472 in. |
| | Ring gap (Oil ring) | D905-EB D1005-EB D1105-EB V1205-EB V1205-T-EB V1305-EB V1505-EB | 0.25 to 0.40 mm 0.0098 to 0.0157 in. | 1.25 mm 0.0492 in. |
| | | D1105-T-EB V1505-T-EB | 0.30 to 0.55 mm 0.0118 to 0.0217 in. | 1.25 mm 0.0492 in. |
| | Piston ring groove to piston ring  | Clearance (Second ring) | All models | 0.085 to 0.112 mm 0.00335 to 0.00441 in. |
| Clearance (Oil ring) | | All models | 0.020 to 0.055 mm 0.00079 to 0.00217 in. | 0.15 mm 0.0059 in. |
| Connecting rod  | Alignment | All models | — | 0.05 mm 0.0020 in. |
| Crankshaft  | Alignment | All models | — | 0.02 mm 0.0008 in. |

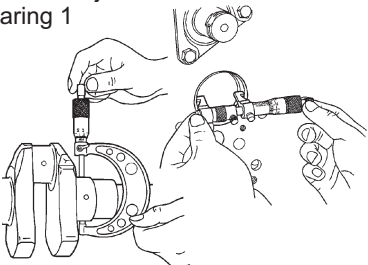
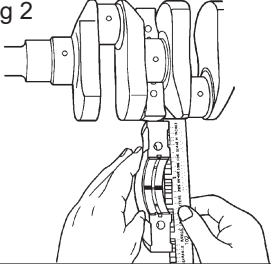
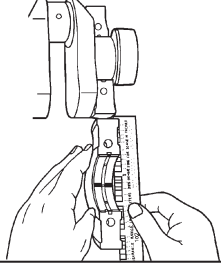
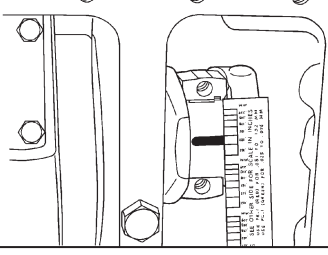
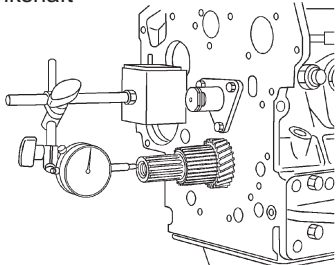
| Item | | | Factory Specification | Allowable Limit |
|---|---------------------------|------------|---|----------------------|
| Crankshaft journal to crankshaft bearing 1  | Oil clearance | All models | 0.034 to 0.114 mm 0.00134 to 0.00449 in. | 0.2 mm 0.0079 in. |
| | Crankshaft journal O.D. | All models | 47.934 to 47.950 mm 1.88716 to 1.88779 in. | — |
| | Crankshaft bearing 1 I.D. | All models | 47.984 to 48.048 mm 1.88913 to 1.89165 in. | — |
| Crankshaft journal to crankshaft bearing 2  | Oil clearance | All models | 0.034 to 0.095 mm 0.00134 to 0.00374 in. | 0.2 mm 0.0079 in. |
| | Crankshaft journal O.D. | All models | 47.934 to 47.950 mm 1.88716 to 1.88779 in. | — |
| | Crankshaft bearing 2 I.D. | All models | 47.984 to 48.029 mm 1.88913 to 1.89090 in. | — |
| Crankshaft journal to crankshaft bearing 3  | Oil clearance | All models | 0.034 to 0.098 mm 0.00134 to 0.00386 in. | 0.2 mm 0.0079 in. |
| | Crankshaft journal O.D. | All models | 51.921 to 51.940 mm 2.04413 to 2.04488 in. | — |
| | Crankshaft bearing 3 I.D. | All models | 51.974 to 52.019 mm 2.04622 to 2.04799 in. | — |
| Crankpin to crankpin bearing  | Oil clearance | All models | 0.029 to 0.091 mm 0.00114 to 0.00358 in. | 0.2 mm 0.0079 in. |
| | Crankpin O.D. | All models | 39.959 to 39.975 mm 1.57319 to 1.57382 in. | — |
| | Crankpin bearing I.D. | All models | 40.004 to 40.050 mm 1.57496 to 1.57677 in. | — |
| Crankshaft  | Side clearance | All models | 0.15 to 0.31 mm 0.0059 to 0.0122 in. | 0.5 mm 0.0197 in. |

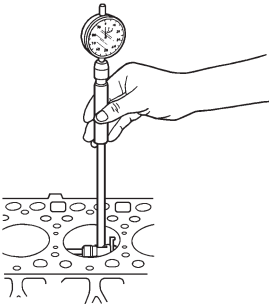
| Item | | Factory Specification | Allowable Limit | |
|---|------------------------------|--|--|--------------------------|
| Cylinder  | Bore I.D. (Standard size) | D905-EB V1205-EB V1205-T-EB | 72.000 to 72.019 mm 2.83464 to 2.83539 in. | 72.169 mm 2.84129 in. |
| | | D1005-EB V1305-EB | 76.000 to 76.019 mm 2.99212 to 2.99287 in. | 76.169 mm 2.99877 in. |
| | | D1105-EB D1105-T-EB V1505-EB V1505-T-EB | 78.000 to 78.019 mm 3.07086 to 3.07161 in. | 78.169 mm 3.07751 in. |
| | Bore I.D. (Oversize) | D905-EB V1205-EB V1205-T-EB | 72.500 to 72.519 mm 2.85433 to 2.85507 in. | 72.669 mm 2.86098 in. |
| | | D1005-EB V1305-EB | 76.500 to 76.519 mm 3.01181 to 3.01255 in. | 76.669 mm 3.01846 in. |
| | | D1105-EB D1105-T-EB V1505-EB V1505-T-EB | 78.5000 to 78.519 mm 3.09055 to 3.09129 in. | 78.669 mm 3.09720 in. |

(2) LUBRICATING SYSTEM

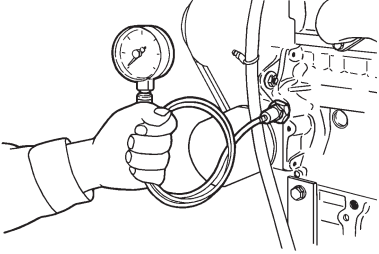
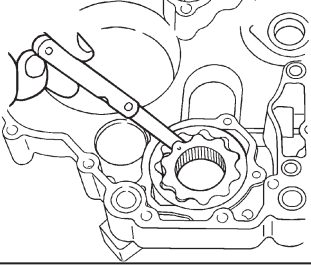
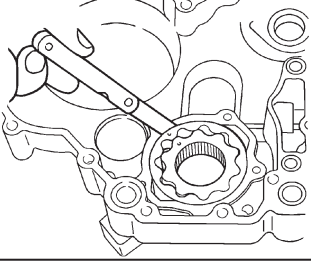
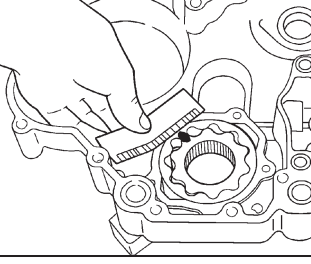
| Item | | Factory Specification | Allowable Limit |
|--|---|--|--|
| Engine oil pressure  | Engine oil pressure (At idle speed) All models | — | 49 kPa 0.5 kgf/cm ² 7 psi |
| | Engine oil pressure (At rated speed) All models | 196 to 441 kPa 2.0 to 4.5 kgf/cm ² 28 to 64 psi | 147 kPa 1.5 kgf/cm ² 21 psi |
| Inner rotor to outer rotor (Oil pump)  | Clearance All models | 0.06 to 0.18 mm 0.0024 to 0.0071 in. | — |
| Outer rotor to pump body (Oil pump)  | Clearance All models | 0.10 to 0.18 mm 0.0039 to 0.0071 in. | — |
| Inner rotor to cover (Oil pump)  | Clearance All models | 0.025 to 0.075 mm 0.00098 to 0.00295 in. | — |

(3) COOLING SYSTEM

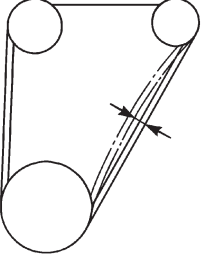
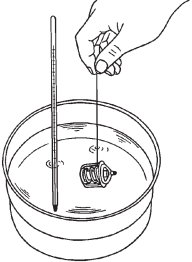
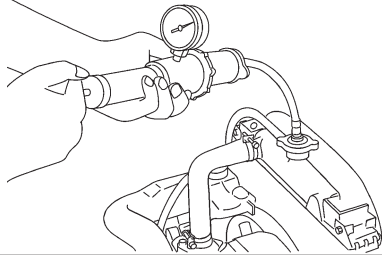
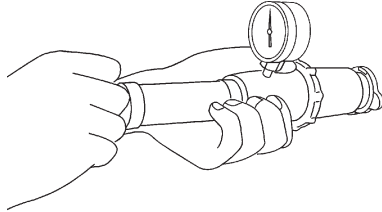
| Item | | | Factory Specification | Allowable Limit |
|---|--|------------|--|-----------------|
| Fan belt  | Tension | All models | 7.0 to 9.0 mm (0.28 to 0.35 in.) deflection at 98 N (10 kgf, 22 lbs) of force | — |
| Thermostat  | Valve opening temperature (At beginning) | All models | 69.5 to 72.5 °C 157.1 to 162.5 °F | — |
| | Valve opening temperature (Opened completely) | All models | 85 °C 185 °F | — |
| Radiator  | Water tightness | All models | No water leak at 137 kPa 1.4 kgf/cm ² 20 psi | — |
| Radiator cap  | Pressure falling time | All models | 10 seconds or more for pressure falling from 88 to 59 kPa (from 0.9 to 0.6 kgf/cm ² , from 13 to 9 psi) | — |

(4) FUEL SYSTEM

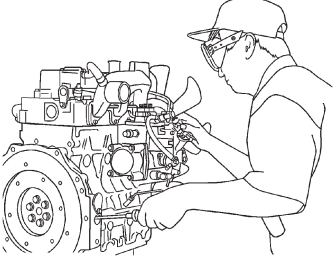
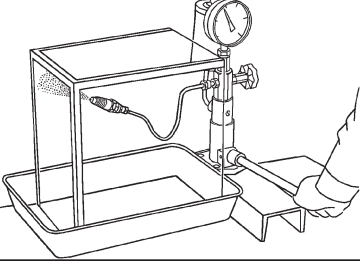
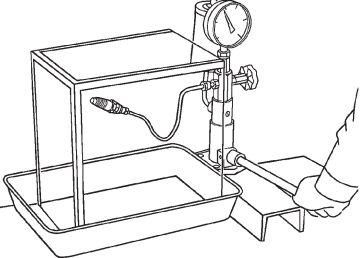
| Item | | Factory Specification | Allowable Limit | |
|---|--|--|---|--|
| Injection pump  | Injection timing (Without timer) | Rated revolution : 3000 min ⁻¹ (rpm) | 0.31 to 0.35 rad. before T.D.C. 18 to 20° before T.D.C. | — |
| | | Rated revolution : 3600 min ⁻¹ (rpm) | 0.37 to 0.40 rad. before T.D.C. 21 to 23° before T.D.C. | — |
| | Injection timing (With timer) | Rated revolution : 3000 min ⁻¹ (rpm) | 0.14 to 0.17 rad. before T.D.C. 8 to 10° before T.D.C. | — |
| | | V1505-EB : 3000 min ⁻¹ (rpm) | 0.21 to 0.24 rad. before T.D.C. 12 to 14° before T.D.C. | — |
| | | Rated revolution : 3600 min ⁻¹ (rpm) | 0.16 to 0.19 rad. before T.D.C. 9 to 11° before T.D.C. | — |
| | Injection nozzle  | Injection pressure | All models | 13.7 to 14.7 MPa 140 to 150 kgf/cm ² 1991 to 2133 psi |
| Injection nozzle  | | | | |

(5) ELECTRICAL SYSTEM

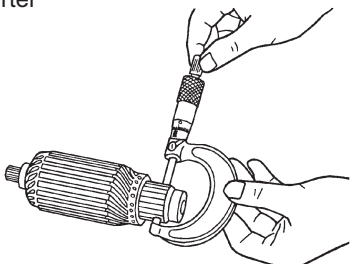
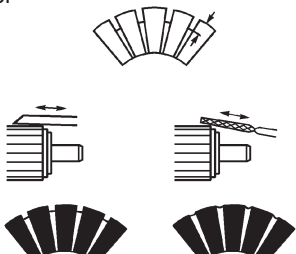
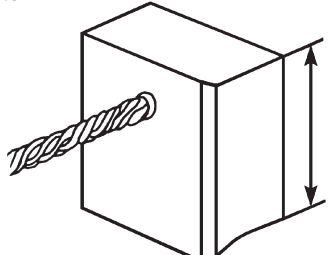
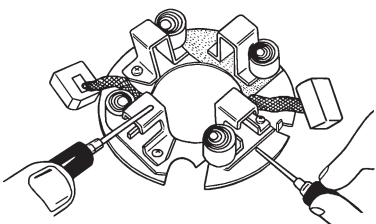
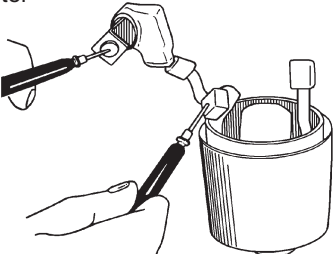
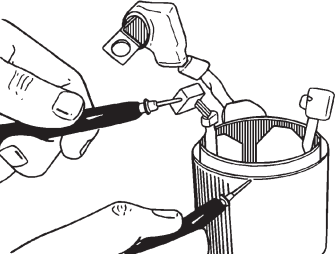
| Item | | | Factory Specification | Allowable Limit |
|--|--|------------|---|-----------------------|
| Starter  | Commutator O.D. | All models | 30.0 mm 1.181 in | 29.0 mm 1.142 in. |
| Starter  | Mica under cut | All models | 0.50 to 0.80 mm 0.0197 to 0.0315 in. | 0.20 mm 0.0079 in. |
| Starter  | Brush length | All models | 13.0 mm 0.5118 in. | 8.5 mm 0.3346 in. |
| Starter  | Brush holder resistance (Brush holder - Holder support) | All models | Infinity | — |
| Starter  | Field coil resistance (Lead - Brush) | All models | Continuity | — |
| Starter  | Field coil resistance (Brush - Yoke) | All models | Infinity | — |

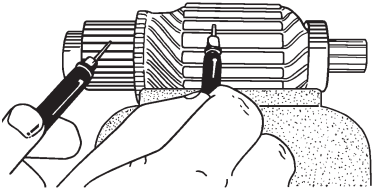
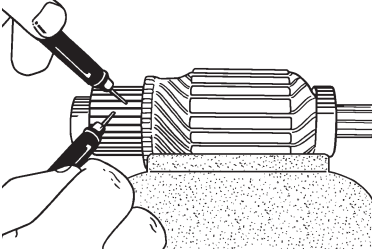
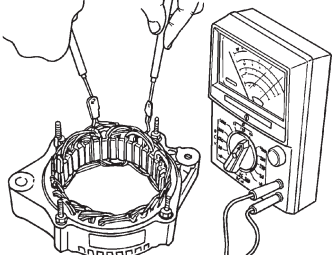
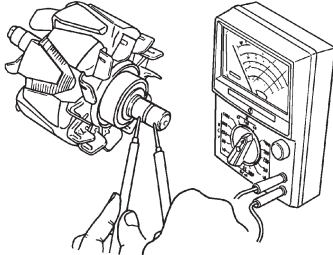
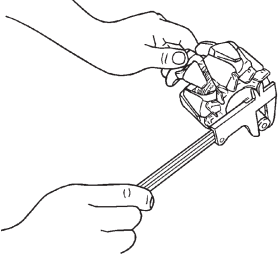
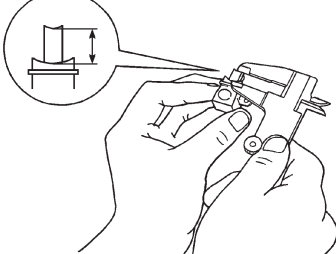
| Item | | | Factory Specification | Allowable Limit |
|---|--|------------|------------------------|----------------------|
| Starter  | Armature coil resistance (Commutator - Armature coil core) | All models | Infinity | — |
| Starter  | Armature coil resistance (Segment - Segment) | All models | Continuity | — |
| Alternator  | Stator resistance | All models | Less than 1.0 Ω | — |
| Alternator  | Rotor resistance | All models | 2.9 Ω | — |
| Alternator  | Slip ring O.D. | All models | 14.4 mm 0.567 in. | 14.0 mm 0.551 in. |
| Alternator  | Brush length | All models | 10.0 mm 0.3937 in. | 1.5 mm 0.0591 in. |

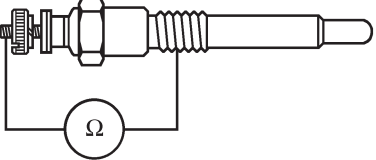
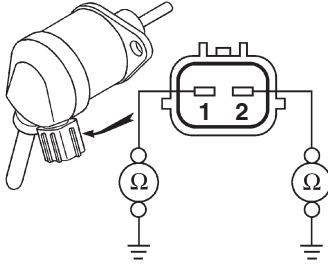
| Item | | | Factory Specification | Allowable Limit |
|--|-----------------------------------|------------|--|-----------------|
| Glow plug  | Resistance | All models | Approx. 1.0 to 1.2 Ω (Serial No. : 489290 & below) | — |
| Stop solenoid  | Resistance (Terminal 1 - body) | All models | Approx. 0.38 Ω | — |
| | Resistance (Terminal 2 - body) | All models | Approx. 15.58 Ω | — |

TIGHTENING TORQUES

(1) Special Tightening Torques

For "*" marked screws, bolts and nuts on under table, apply engine oil to their threads and seats before tightening.

Cylinder head cover nut *

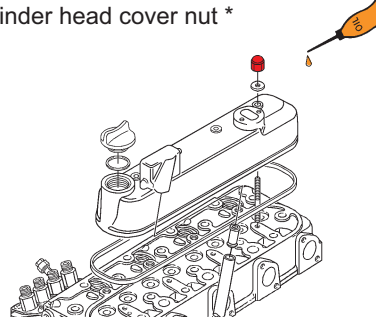

| | |
|------------|-------------------|
| D905-EB | |
| D1005-EB | |
| D1105-EB | |
| D1105-T-EB | 6.9 to 8.8 N·m |
| V1205-EB | 0.7 to 0.9 kgf·m |
| V1205-T-EB | 5.1 to 6.5 ft-lbs |
| V1305-EB | |
| V1505-EB | |
| V1505-T-EB | |

Main bearing case screw 1 *

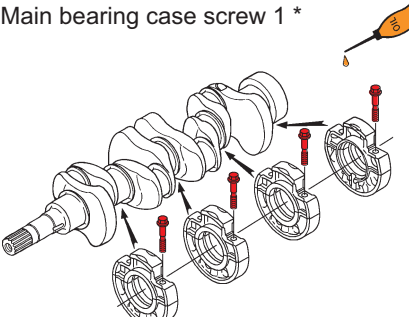

| | |
|------------|---------------------|
| D905-EB | |
| D1005-EB | |
| D1105-EB | |
| D1105-T-EB | 29.4 to 34.3 N·m |
| V1205-EB | 3.0 to 3.5 kgf·m |
| V1205-T-EB | 21.7 to 25.3 ft-lbs |
| V1305-EB | |
| V1505-EB | |
| V1505-T-EB | |

Main bearing case screw 2 *

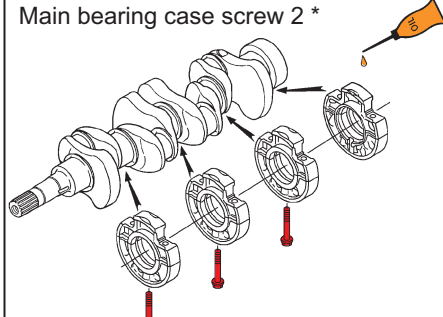

| | |
|------------|---------------------|
| D905-EB | |
| D1005-EB | |
| D1105-EB | |
| D1105-T-EB | 49.0 to 53.9 N·m |
| V1205-EB | 5.0 to 5.5 kgf·m |
| V1205-T-EB | 36.2 to 39.8 ft-lbs |
| V1305-EB | |
| V1505-EB | |
| V1505-T-EB | |

Cylinder head screw *

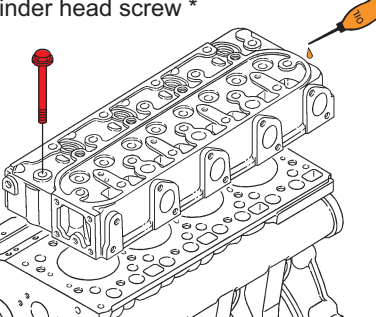

| | |
|------------|---------------------|
| D905-EB | |
| D1005-EB | |
| D1105-EB | |
| D1105-T-EB | 63.7 to 68.6 N·m |
| V1205-EB | 6.5 to 7.0 kgf·m |
| V1205-T-EB | 47.0 to 50.6 ft-lbs |
| V1305-EB | |
| V1505-EB | |
| V1505-T-EB | |

Cylinder head tightening order

(A) 3 cylinder model

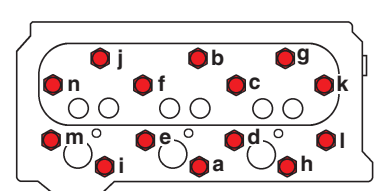

(B) 4 cylinder model

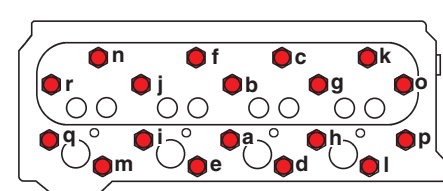

| | |
|------------|-------------------------------|
| D905-EB | |
| D1005-EB | |
| D1105-EB | |
| D1105-T-EB | (A) 3 cylinder model a → n |
| V1205-EB | (B) 4 cylinder model a → r |
| V1205-T-EB | |
| V1305-EB | |
| V1505-EB | |
| V1505-T-EB | |

Flywheel screw *

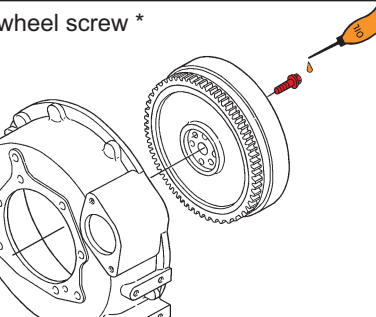

| | |
|------------|---------------------|
| D905-EB | |
| D1005-EB | |
| D1105-EB | |
| D1105-T-EB | 53.9 to 58.8 N·m |
| V1205-EB | 5.5 to 6.0 kgf·m |
| V1205-T-EB | 39.8 to 43.4 ft-lbs |
| V1305-EB | |
| V1505-EB | |
| V1505-T-EB | |

Connecting rod screw *

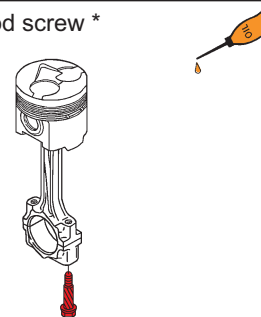

| | |
|------------|---------------------|
| D905-EB | |
| D1005-EB | |
| D1105-EB | |
| D1105-T-EB | 41.2 to 46.1 N·m |
| V1205-EB | 4.2 to 4.7 kgf·m |
| V1205-T-EB | 30.4 to 34.0 ft-lbs |
| V1305-EB | |
| V1505-EB | |
| V1505-T-EB | |

Rocker arm bracket nut *

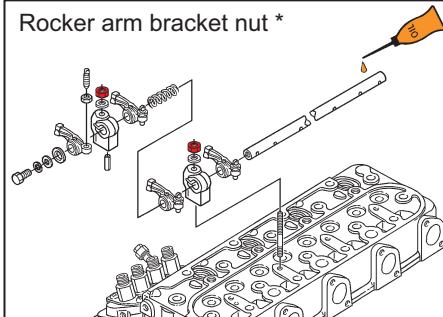

| | |
|------------|---------------------|
| D905-EB | |
| D1005-EB | |
| D1105-EB | |
| D1105-T-EB | 21.6 to 26.5 N·m |
| V1205-EB | 2.2 to 2.7 kgf·m |
| V1205-T-EB | 15.9 to 19.5 ft-lbs |
| V1305-EB | |
| V1505-EB | |
| V1505-T-EB | |

Idle gear shaft screw *

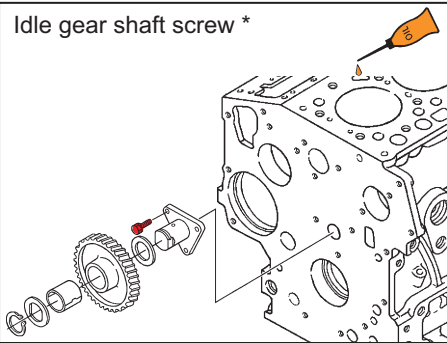

| | |
|------------|--------------------|
| D905-EB | |
| D1005-EB | |
| D1105-EB | |
| D1105-T-EB | 9.8 to 11.3 N·m |
| V1205-EB | 1.00 to 1.15 kgf·m |
| V1205-T-EB | 7.2 to 8.3 ft-lbs |
| V1305-EB | |
| V1505-EB | |
| V1505-T-EB | |

Bearing case cover screw *

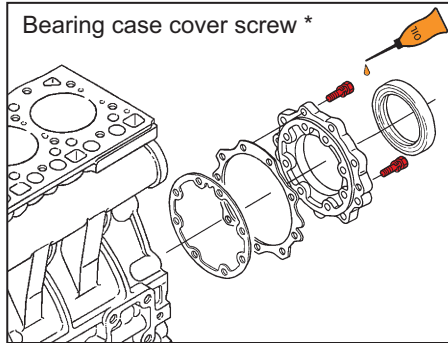

| | |
|------------|--------------------|
| D905-EB | |
| D1005-EB | |
| D1105-EB | |
| D1105-T-EB | 9.8 to 11.3 N·m |
| V1205-EB | 1.00 to 1.15 kgf·m |
| V1205-T-EB | 7.2 to 8.3 ft-lbs |
| V1305-EB | |
| V1505-EB | |
| V1505-T-EB | |

Fan drive pulley screw

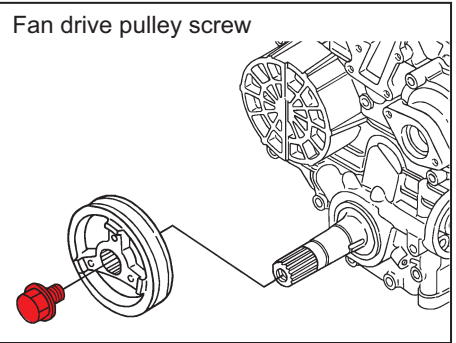

| | |
|------------|-------------------------------|
| D905-EB | |
| D1005-EB | 142.2 to 152.0 N·m |
| D1105-EB | 14.5 to 15.5 kgf·m |
| D1105-T-EB | 104.9 to 112.1 ft-lbs |
| V1205-EB | (Serial No. : 604086 & below) |
| V1205-T-EB | |
| V1305-EB | 235.4 to 245.2 N·m |
| V1305-T-EB | 24.0 to 25.0 kgf·m |
| V1505-EB | 173.6 to 180.8 ft-lbs |
| V1505-T-EB | (Serial No. : 604087 & above) |

Glow plug

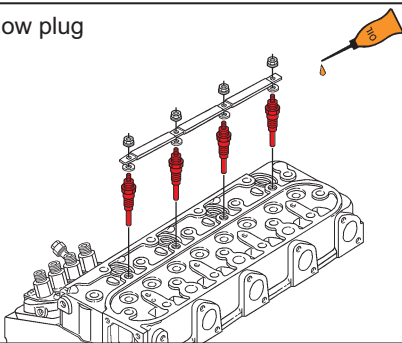

| | |
|------------|-------------------------------|
| D905-EB | |
| D1005-EB | 19.6 to 24.5 N·m |
| D1105-EB | 2.0 to 2.5 kgf·m |
| D1105-T-EB | 14.5 to 18.1 ft-lbs |
| V1205-EB | (Serial No. : 489290 & below) |
| V1205-T-EB | |
| V1305-EB | 7.8 to 14.7 N·m |
| V1305-T-EB | 0.8 to 1.5 kgf·m |
| V1505-EB | 5.8 to 10.8 ft-lbs |
| V1505-T-EB | (Serial No. : 489291 & above) |

Nozzle holder assembly

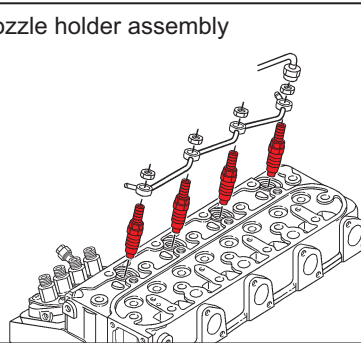

| | |
|------------|---------------------|
| D905-EB | |
| D1005-EB | |
| D1105-EB | |
| D1105-T-EB | 49.0 to 68.6 N·m |
| V1205-EB | 5.0 to 7.0 kgf·m |
| V1205-T-EB | 36.2 to 50.6 ft-lbs |
| V1305-EB | |
| V1505-EB | |
| V1505-T-EB | |

Oil switch taper screw

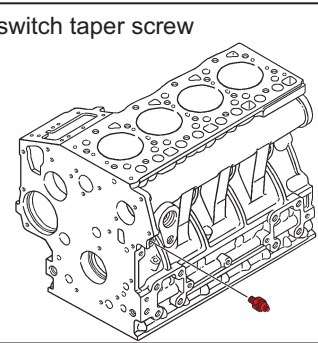

| | |
|------------|---------------------|
| D905-EB | |
| D1005-EB | |
| D1105-EB | |
| D1105-T-EB | 14.7 to 19.6 N·m |
| V1205-EB | 1.5 to 2.0 kgf·m |
| V1205-T-EB | 10.8 to 14.5 ft-lbs |
| V1305-EB | |
| V1505-EB | |
| V1505-T-EB | |

Injection pipe retaining nut

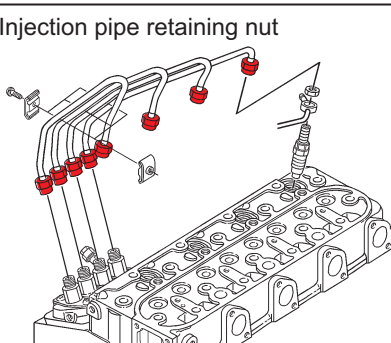

| | |
|------------|---------------------|
| D905-EB | |
| D1005-EB | |
| D1105-EB | |
| D1105-T-EB | 24.5 to 34.3 N·m |
| V1205-EB | 2.5 to 3.5 kgf·m |
| V1205-T-EB | 18.1 to 25.3 ft-lbs |
| V1305-EB | |
| V1505-EB | |
| V1505-T-EB | |

Overflow pipe assembly retaining nut

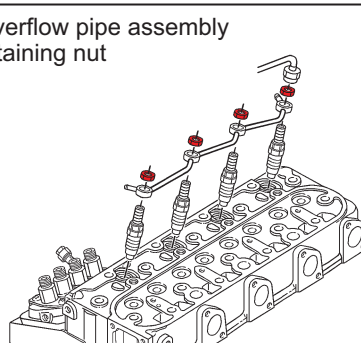

| | |
|------------|---------------------|
| D905-EB | |
| D1005-EB | |
| D1105-EB | |
| D1105-T-EB | 19.6 to 24.5 N·m |
| V1205-EB | 2.0 to 2.5 kgf·m |
| V1205-T-EB | 14.5 to 18.1 ft-lbs |
| V1305-EB | |
| V1505-EB | |
| V1505-T-EB | |

Camshaft set screw

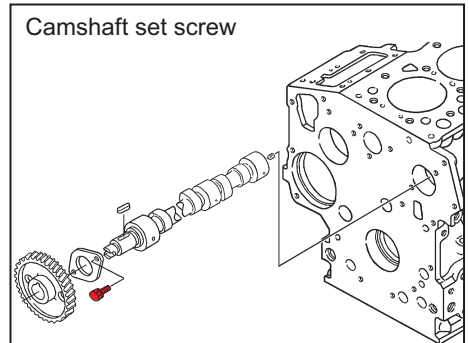

| | |
|------------|---------------------|
| D905-EB | |
| D1005-EB | |
| D1105-EB | |
| D1105-T-EB | 23.5 to 27.5 N·m |
| V1205-EB | 2.4 to 2.8 kgf·m |
| V1205-T-EB | 17.4 to 20.3 ft-lbs |
| V1305-EB | |
| V1505-EB | |
| V1505-T-EB | |

Alternator pulley nut

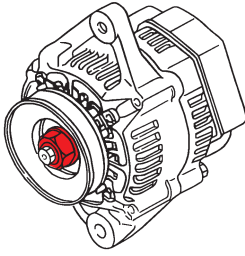

| | |
|------------|---------------------|
| D905-EB | |
| D1005-EB | |
| D1105-EB | |
| D1105-T-EB | 58.3 to 78.9 N·m |
| V1205-EB | 5.95 to 8.05 kgf·m |
| V1205-T-EB | 43.0 to 58.2 ft-lbs |
| V1305-T-EB | |
| V1505-EB | |
| V1505-T-EB | |

(2) General Tightening Torques

Screw and bolt material grades are shown by numbers punched on the screw and bolt heads.

Prior to tightening, be sure to check out the numbers as shown below.

None or 4 : Standard grade

7 : Special grade

| Nominal Diameter | Standard Grade | Special Grade |
|------------------|---|--|
| M6 | 7.9 to 9.3 N·m 0.80 to 0.95 kgf·m 5.8 to 6.9 ft-lbs | 9.8 to 11.3 N·m 1.00 to 1.15 kgf·m 7.23 to 8.32 ft-lbs |
| M8 | 17.7 to 20.6 N·m 1.8 to 2.1 kgf·m 13.0 to 15.2 ft-lbs | 23.5 to 27.5 N·m 2.4 to 2.8 kgf·m 17.4 to 20.3 ft-lbs |
| M10 | 39.2 to 45.1 N·m 4.0 to 4.6 kgf·m 28.9 to 33.3 ft-lbs | 48.1 to 55.9 N·m 4.9 to 5.7 kgf·m 35.4 to 41.2 ft-lbs |
| M12 | 62.8 to 72.6 N·m 6.4 to 7.4 kgf·m 46.3 to 53.5 ft-lbs | 77.5 to 90.2 N·m 7.9 to 9.2 kgf·m 57.1 to 66.5 ft-lbs |