

INDUSTRIAL GASOLINE ENGINE

Kubota WG Series (3-Cylinder)

WG752-G-E3

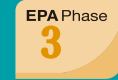

Rated Power

18.5 kW @ 3600 rpm



Photograph may show non-standard equipment.

Performance Curves

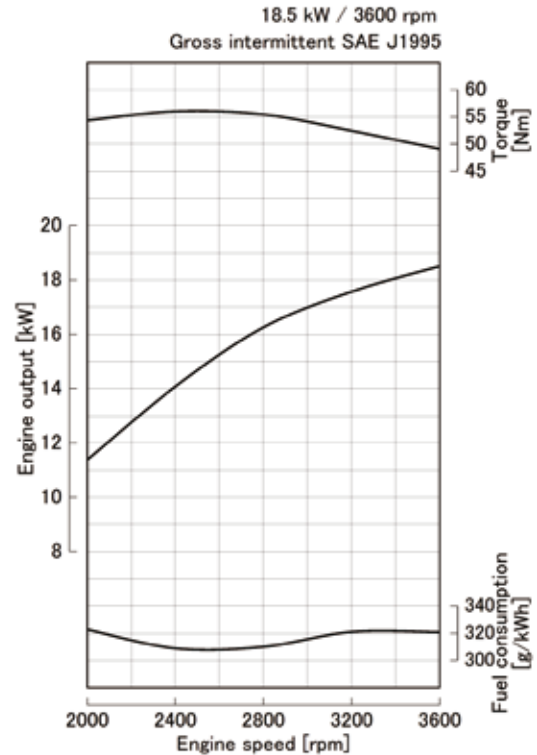

Features and Benefits

Emissions

Kubota's WG752-G-E3 engine has been designed to comply with EPA Phase 3 / CARB Phase 3 + EU Stage V.

Fuel Flexibility

The installation compatibility that exists between Spark-Ignition engines (SI) and Compression-Ignition engines (CI) is convenient for customers who need fuel flexibility for their products. The Kubota WG Series includes a gasoline version and a dual fuel (gasoline and LPG) version.

Durability and Reliability

Kubota's WG Series small SI engines are designed after the Kubota Super Mini Series diesel (CI) engines, which are known worldwide as reliable industrial engines. The WG752 engines provide an easy transition from engine models for previous emission standards by keeping the same footprint while offering excellent performance.

WG752-G-E3

Engine Specifications

Engine model		WG752-G-E3
Emission regulation		EPA Phase 3 CARB Phase 3 + EU Stage V
Type		Vertical, water cooled 4-cycle spark ignited engine
Fuel type		Gasoline
Cylinders		3
Bore and stroke	mm (in)	68.0 x 68.0 (2.68 x 2.68)
Displacement	L (cu.in)	0.740 (45.2)
Aspiration		Naturally aspirated
Aftertreatment		Three-way catalyst
Rated output / speed *1	kW (HP) / rpm	18.5 (24.8) / 3600
Maximum torque / speed *1	Nm (lb-ft) / rpm	56.0 (41.3) / 2400
Length x Width x Height *2	mm (in)	410 x 397 x 540 (16.1 x 15.6 x 21.3)
Dry weight *2	kg (lbs)	62 (137)

Specifications are subject to change without notice.
Dimensions and dry weight are according to Kubota's standard specification.
Dimensions and weight depend on completed specifications.
LPG: Commercial liquid propane gas only. Equivalent to propane HD-5 of GPA standard.
Natural gas: The performance shown is with Japanese standard natural gas.

*1: SAE J1995 gross intermittent

*2: Exclude cooling fan and exclude aftertreatment unit

Dimensions

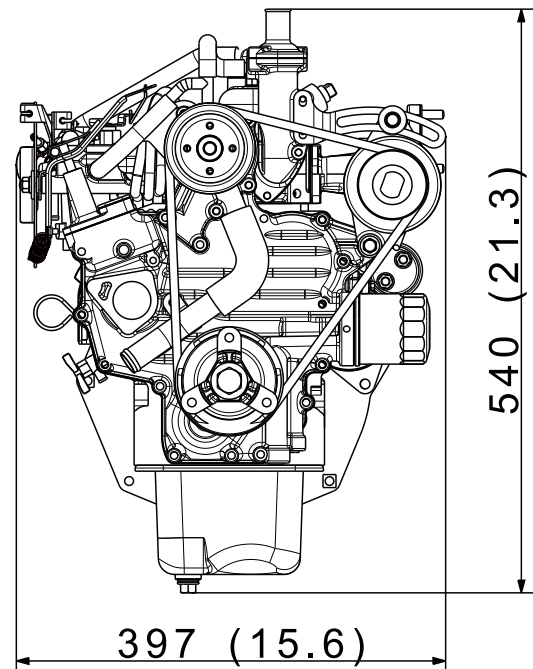
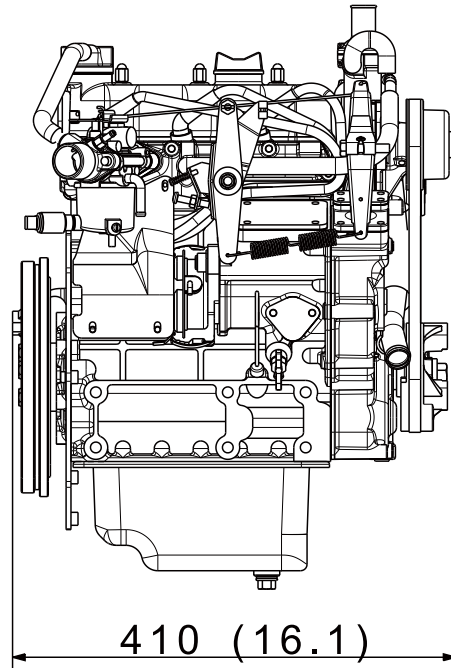

Kubota Corporation

2-47, Shikitsuhigashi 1-chome Naniwa-ku, Osaka, 556-8601 Japan
<https://global.engine.kubota.co.jp/en/>

ASPWG752-G-E31906-R2-I-170021