

## INDUSTRIAL DIESEL ENGINE

### Kubota 07 Series (4-Cylinder)

# V3307-CR-TI-E5



#### Rated Power

## 55.4 kW @ 2600 rpm

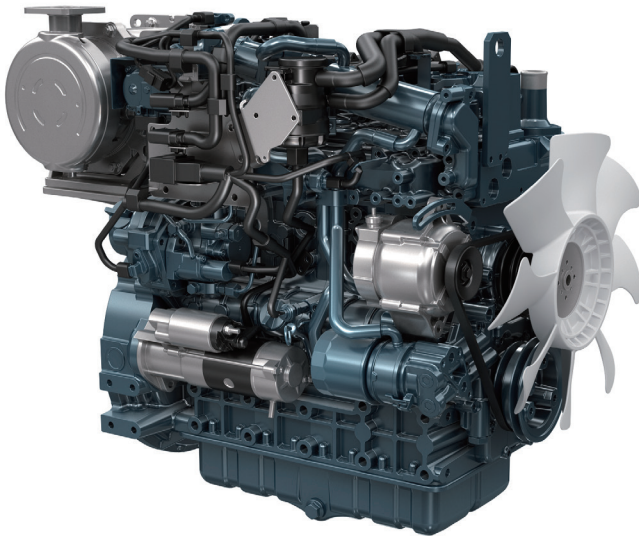

Photograph may show non-standard equipment.

#### Performance Curves

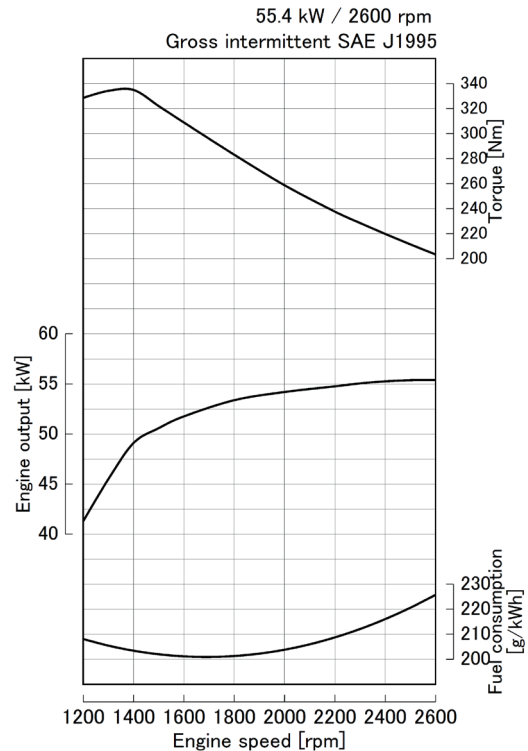

#### Features and Benefits

##### Emissions Compliance

Meeting rigid emissions regulations can be a challenge for any company. V3307-CR-TI-E5 engines have been designed to comply with stringent regulations: EPA/CARB Tier4 + EU Stage V.

##### Advanced DPF Technology

Diesel Particulate Filters (DPF) are essential to meeting EU Stage V emission regulations. With many years of experience in DPF engines, Kubota has developed a DPF technology that enables automatic regeneration even at a low rpms, giving your product a competitive edge.

The technology has also made long service intervals possible, helping to minimize downtime and maintenance worries.

##### Compact but High Power

V3307-CR-TI-E5 delivers high power but it is still kept compact and reliable. A common rail system has made it possible to optimize combustion and create a quieter engine with high fuel efficiency, while an intercooler-turbo delivers high power density. By meticulously screening and controlling the exhaust gas aftertreatment components, we are able to offer a compact, high-performance and reliable engine.

##### Great Flexibility

Providing global solutions with great flexibility is a must when working with customers in different countries who have different engine needs. Kubota 07 Series engines have evolved every step of the way in meeting the requirements of each EPA Tier. As such, we are able to provide our customers worldwide with engines certified for the appropriate emissions regulations.

In addition, we have designed aftertreatment units with minimum impact for easy installation. The Kubota 07 Series is the ideal solution for your company's global marketing strategy.

For Earth, For Life  
**Kubota**

## Engine Specifications

## Dimensions

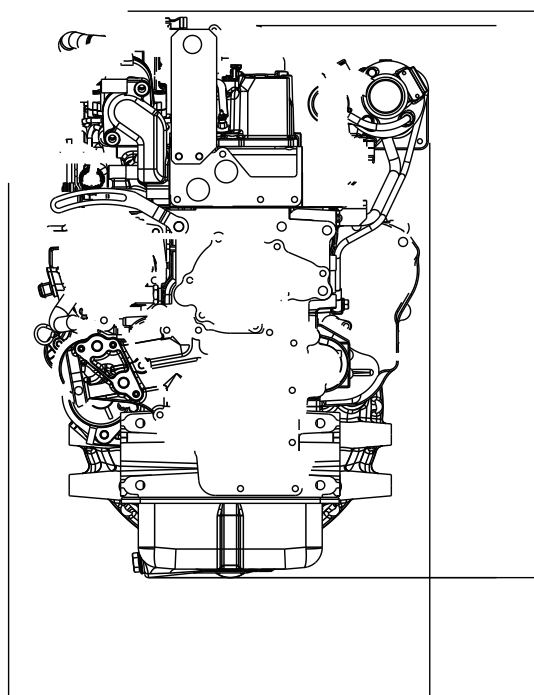
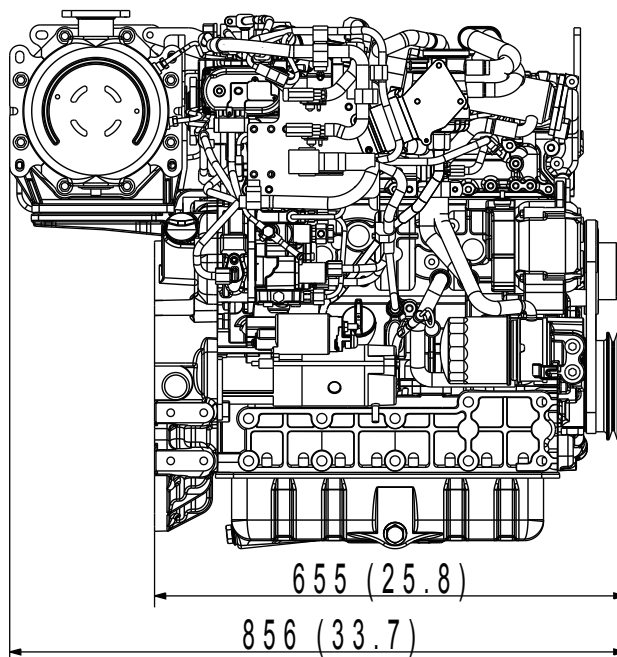

## Kubota Corporation

2-47, Shikitsuhigashi 1-chome Naniwa-ku, Osaka, 556-8601 Japan

<https://global.engine.kubota.co.jp/en/>